

Air Mover parts list Issue C

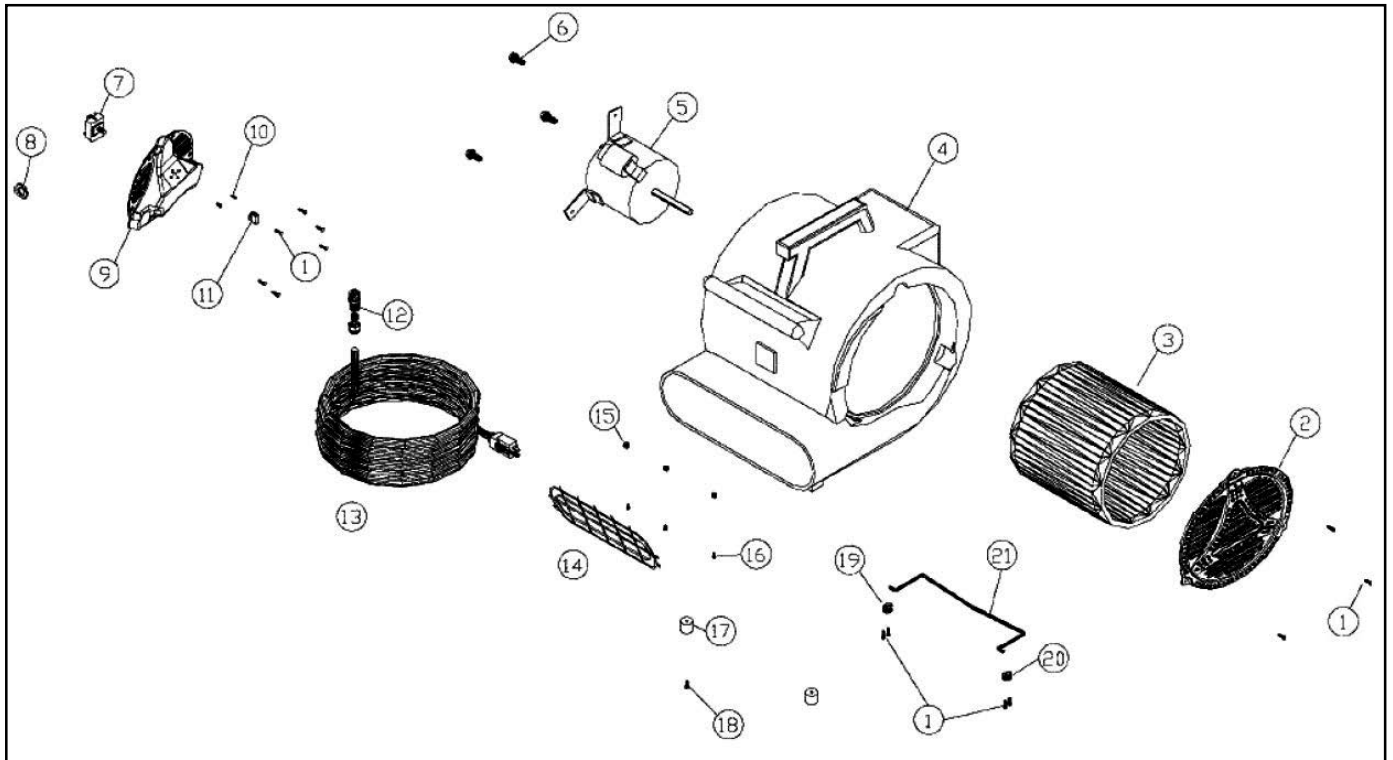

Ref no	Part no	Description	Ref no	Part no	Description
1	X8261	screw #6 x 1/2 phil pan type a	11	PD1K	knob, switch
2	X8872	intake panel	12	PD8	strain relief 1/2" npt
3	X8873	squirrel cage w/locknut AM	13	X8926	6m 115v cord set
4	X8876	dryer housing		PD7E	6m 230v cord set
5	X8997	dryer motor and capacitor 230v		PD7E/EURO	6m 230v cord set euro plug
	X8881	dryer motor and capacitor 110v	14	X8871	dryer discharge
6	X8964	screw 3/8-16 x 1/2	15	X8256	nut 8-32 lock w/nylon insert
7	X8897	switch 110v	16	X8278	screw 8-32 x 1/2 phil pan
	X9329	switch 230v	17	PD3B	foot, black rubber, new style
8	X8008N	nut, lock, 1/2" steel conduit	18	PX73	screw 8-32 x 1 phil pan
9	X8875	motor control panel	19	X8928	right tilt stand foot
10	X8903	m4x6 flat head Phillips screw	20	X8929	left tilt stand foot
			21	X8874	kickstand
				X8990	handle and wheels for "T" model
				X8973-TV	dryer housing label 2 off

**SCHEMATIC USED
FOR THE FOLLOWING
MACHINES:**

PD500+	PD750-R+	AM/110+	-
PD500DX+	PD750DX+	-	-
PD500-Y+	PD500DX-YS+	-	-
PD750+	PD350+	-	-

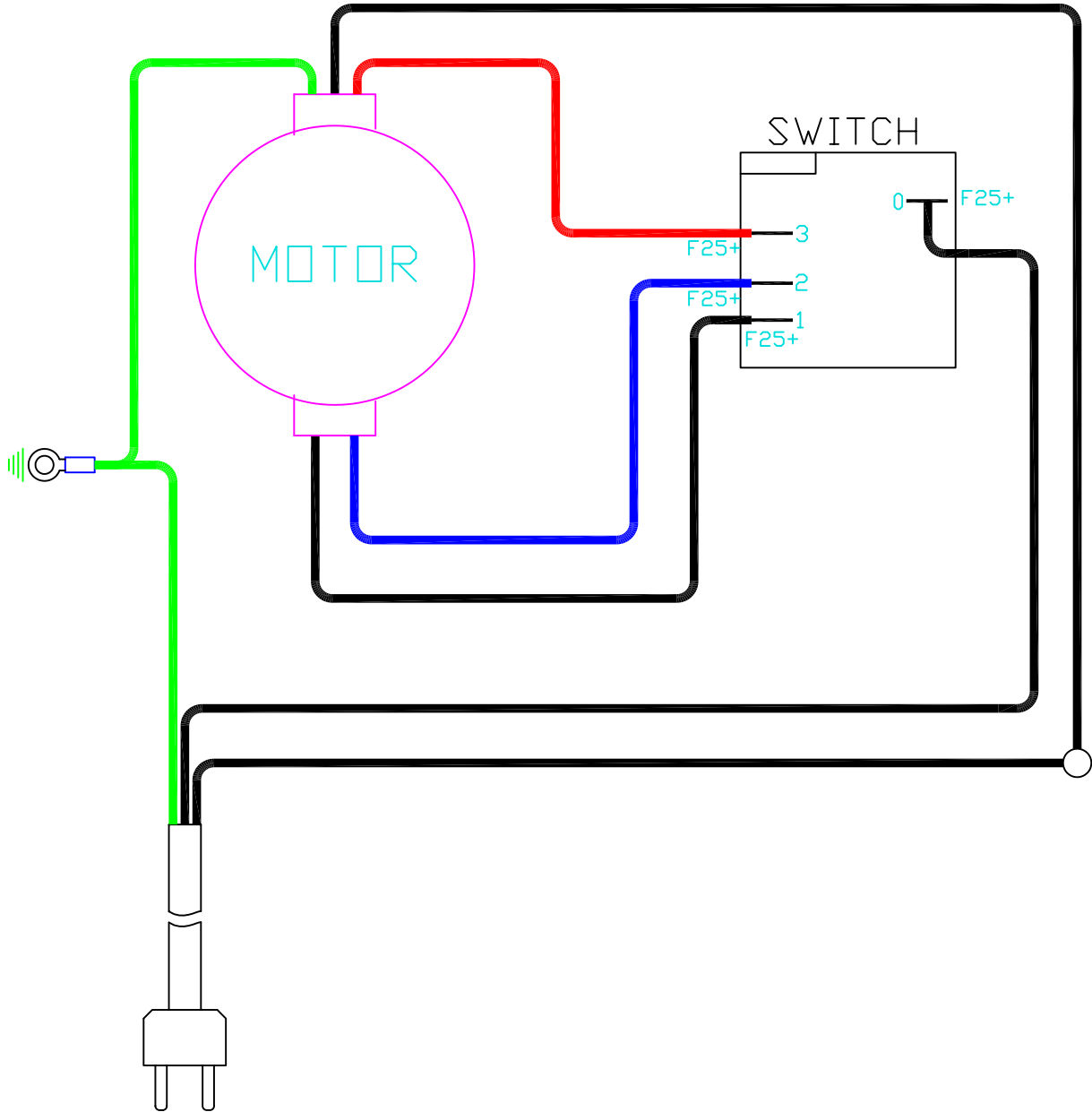

REV	DATE	ECN	DESCRIPTION	BY	<i>Powr-Flite</i> COMMERCIAL FLOOR CARE EQUIPMENT		3101 Wichita Court Fort Worth, TX 76140-1755			
-	-	-	-	-	MATERIAL	-	FINISH	-	SCALE	-
B	3/25/09	-	ADDED AM/110+ MACHINE	GS	DWN	AR	DATE	5/11/07	SHT	1 of 2
<small>XX ±0.02 IN RADIUS XX ±0.02 XXX ±0.01 IN XXX ±0.01 XXXX ±0.005 IN. COMMON CONCENTRIC XXXX ±0.0005 IN. TO 0.002" ± 0°30'</small>					<small>POWR-FLITE CORPORATION CLAIMS PROPRIETARY RIGHTS IN THE MATERIAL DISCLOSED HEREIN. THIS DRAWING IS ISSUED FOR ENGINEERING INFORMATION ONLY. IT MAY NOT BE REPRODUCED, NOR MAY THE INFORMATION HEREIN BE USED FOR MANUFACTURING PURPOSES WITHOUT WRITTEN PERMISSION FROM POWR-FLITE CORP.</small>					
A PART NUMBER					WPF007					
WIRING DIAGRAM					REV B					

**SCHEMATIC USED
FOR THE FOLLOWING
MACHINES:**

PD500-2+	BS50SDXE	CFR2500-2	.
PD500DX-2+	AM/T+	-	.
PD500DX-YS2+	AM+	-	.
BS50SDE	PD2500-2+	-	.

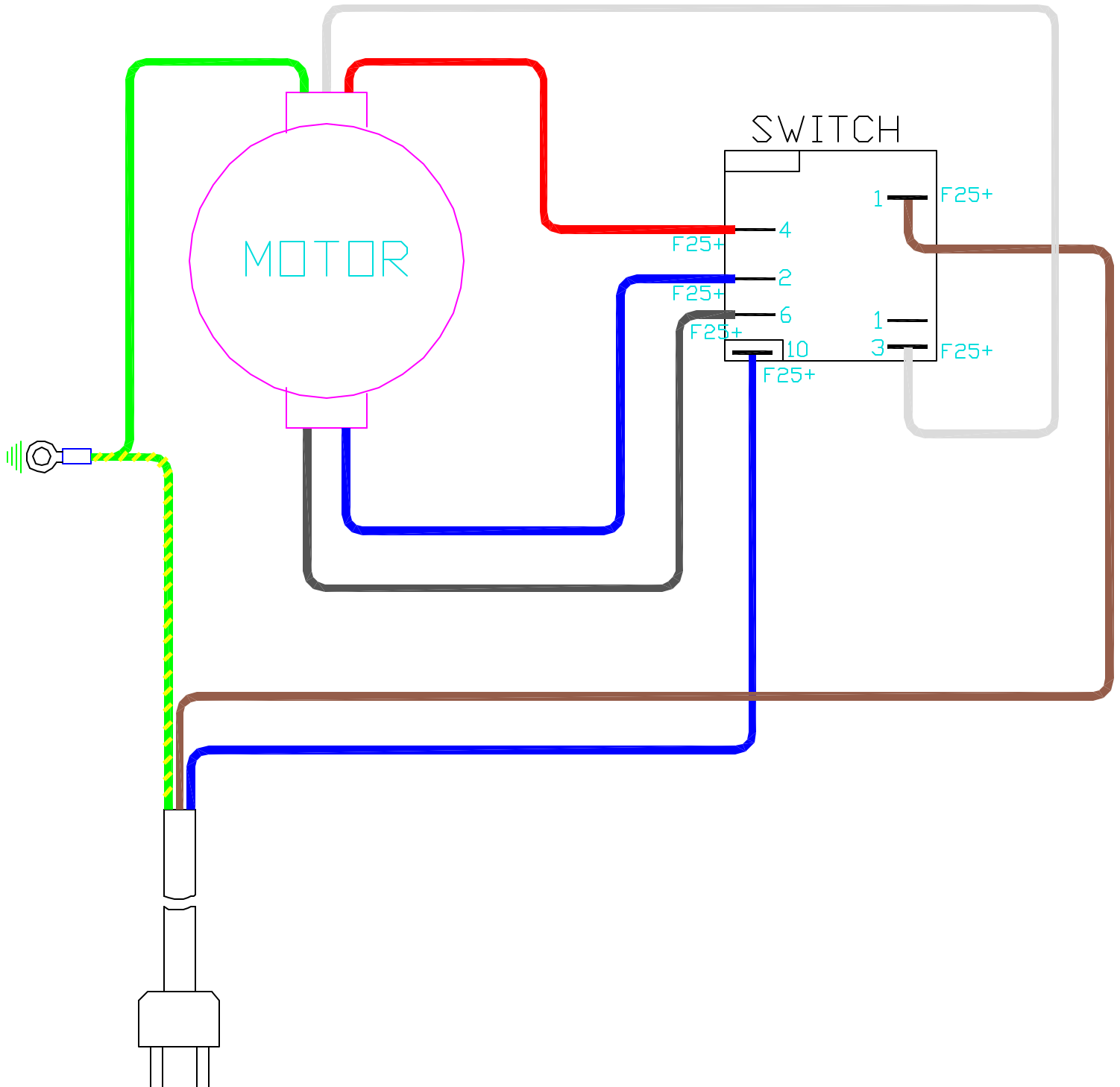

REV	DATE	ECN	DESCRIPTION	BY	Powr-Flite	3101 Wichita Court	
.	COMMERCIAL FLOOR CARE EQUIPMENT	Fort Worth, TX 76140-1755	
.	MATERIAL	FINISH	SCALE
.	DWN CSD	DATE 12/4/06	BHT 1 OF 2
<small> XX ±0.02 IN RADI XX ±0.02 XXX ±0.01 IN XXX ±0.01 XXXX ±0.003 IN. COMMON CONCENTRIC XXXXX ±0.0005 IN. TO .0001" ± 0-20" BREAK SHARP EDGES TO .010 MAX. </small>					DESCRIPTION WIRING DIAGRAM - 230V WPF007		REV 00